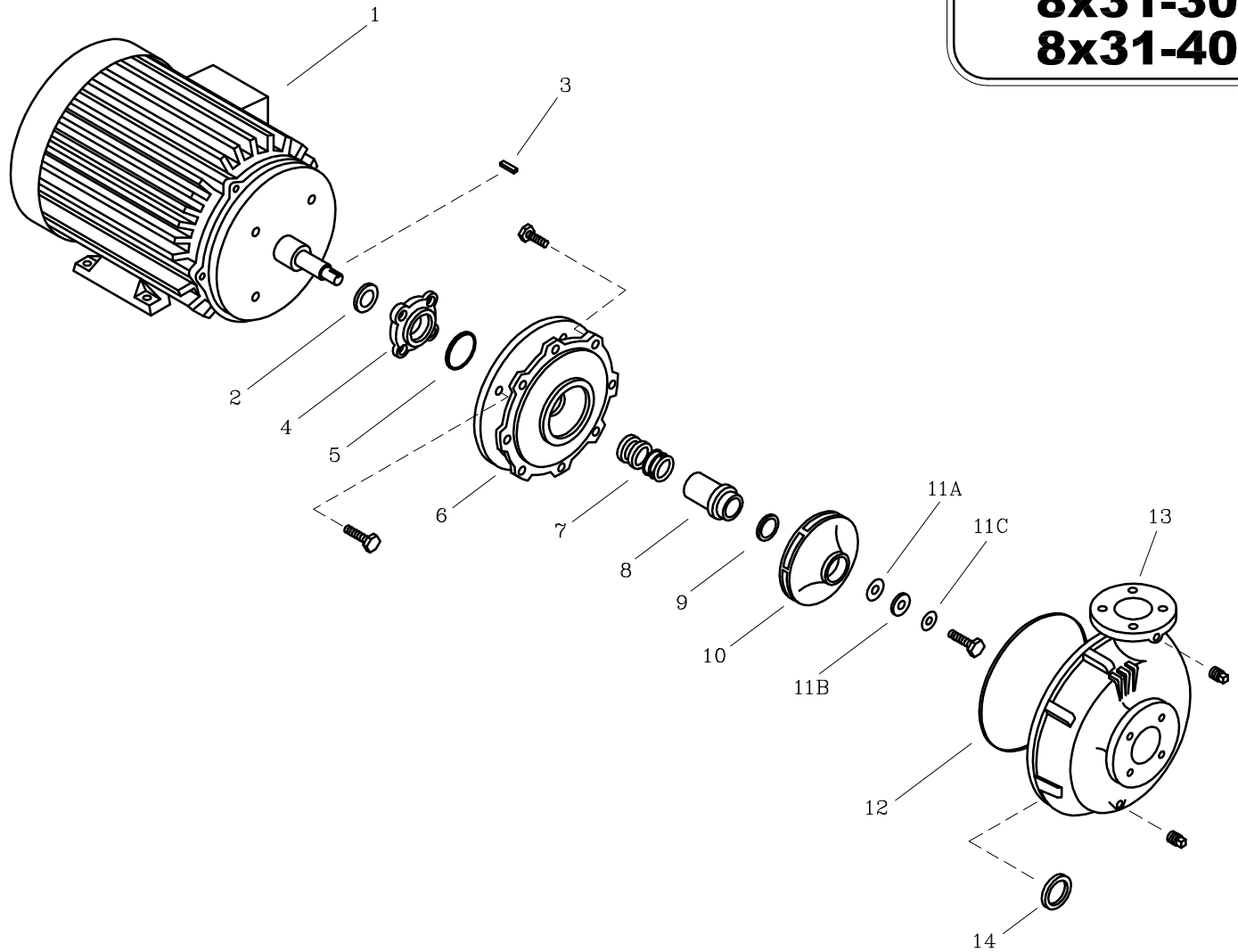

8x31-25**8x31-30****8x31-40**

LISTA DE REPUESTOS			CANTIDAD		
ITEM No.	DESCRIPCION	CODIGO	8x31-25W	8x31-30W	8x31-40
* 1	MOTOR ELECTRICO 1750 RPM	SEGUN POTENCIA	1	1	1
2	DEFLECTOR 43.5 mm. DIA. INT.	7800600051	1	1	1
3	CUÑA 1/4"x45 mm.	7711500041	1	1	1
4	PRENSA SELLO EUROLINEA T2-256	03041B0021	1	1	1
5	AROSSELLO REF. 2-150	0306000051	1	1	1
6	PLATO SELLO EUROLINEA T2-286JM	0307400021	1	1	1
7	SELLO MECANICO ϕ 1.1/2" TIPO 21	7712000051	1	1	1
8	CASQUILLO S.M. 5x31-25	89174B0041	1	1	1
9	AROSSELLO ROTOR	7711300051	1	1	1
10	ROTOR 8x31-25 300 mm.	03079A1021	1	-	-
10	ROTOR 8x31-30 315 mm.	03079A0021	-	1	-
10	ROTOR 8x31-40 330 mm.	0307900021	-	-	1
11A	EMPAQUE ARANDELA ROTOR 5x20	8836800043	1	1	1
11B	ARANDELA ROTOR 17/32" DIA. INT.	8836500041	1	1	1
11C	ARANDELA DE COBRE 17/32"	8837700056	1	1	1
12	EMPAQUE CARCASA 6x31	9200200043	1	1	1
13	CARCASA ANILLO 8x31	8717300021	1	1	1
14	ANILLO DE FRICCION 8x31	8717400022	1	1	1

* Para servicio o reparacion del motor, tenga en cuenta el modelo y características contenidas en la placa del mismo.
 - Tornilleria estandar se ilustra unicamente.