

15HH-L2
20HH-L2

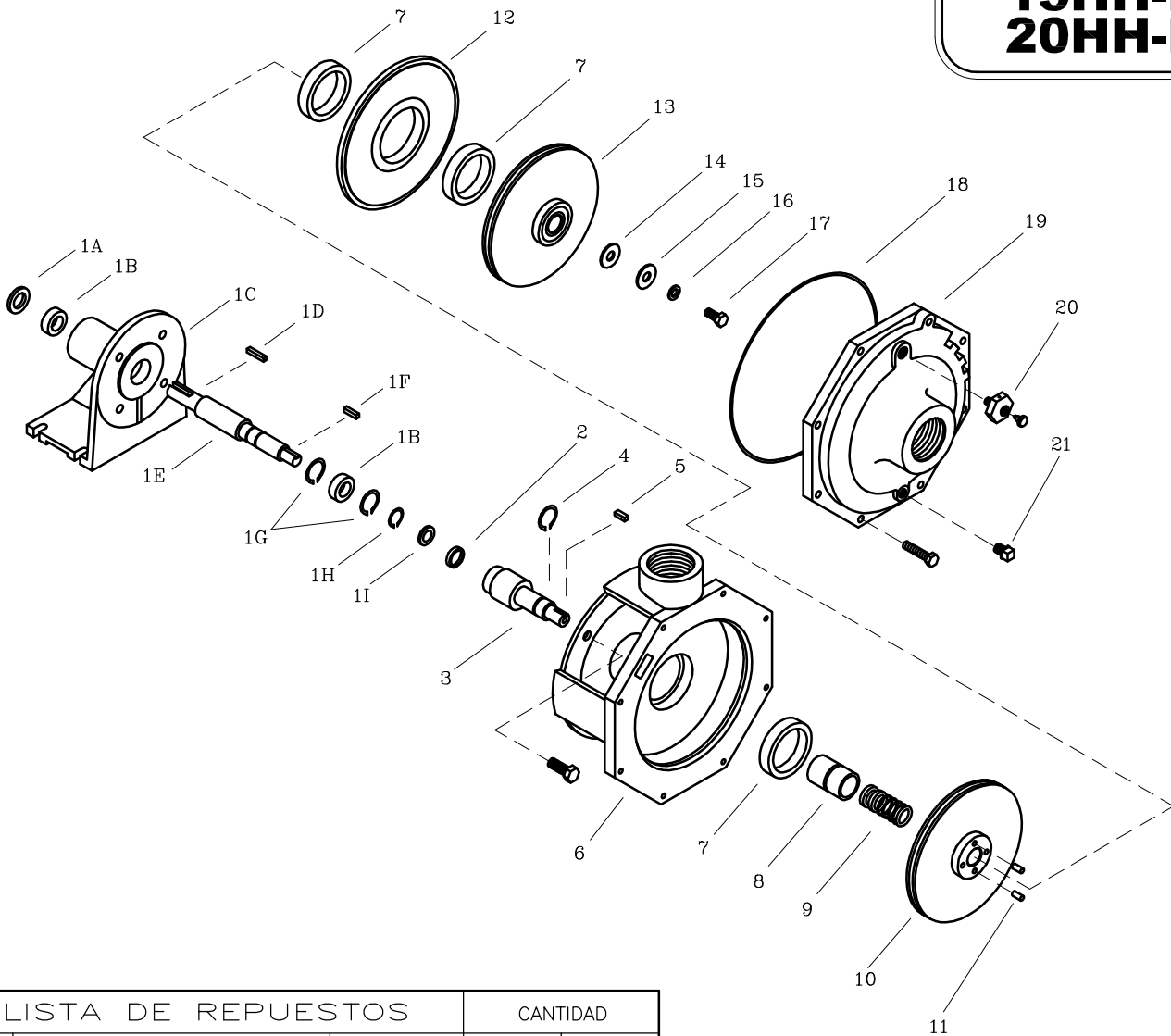

LISTA DE REPUESTOS

CANTIDAD

ITEM No.	DESCRIPCION	CODIGO	CANTIDAD	
			15HH-L2	20HH-L2
*1	SOPORTE COMPLETO L2	9802700046	1	1
2	DEFLECTOR 29.3 mm. DIA. INT.	7220000051	1	1
3	EJE EXTENSION 20HH	9601400041	1	1
4	ANILLO RETEN. ROD. A-38	8703500052	1	1
5	CUÑA 3/16"x25 mm.	7707100041	1	1
6	CARCASA ANILLO 15HH	9602200021	1	-
6	CARCASA ANILLO 20HH	9600600021	-	1
7	ANILLO DE FRICCION 3A/32	8726700022	3	-
7	ANILLO DE FRICCION 30HH	93011A0022	-	3
8	CASQUILLO S.M. 1.1/2" 15HH	9601600041	1	-
8	CASQUILLO S.M. 1.1/2" 20HH	96016A0041	-	1
9	SELLO MECANICO 1.1/2" TIPO 21	7712000051	1	1
10	ROTOR II 15 HH 180 mm.	9602100021	1	-
10	ROTOR II 20 HH 195 mm CUÑERO	9601100021	-	1
11	PIN ROTOR 20HH	96013000044	4	4
12	PLATO INTERMEDIO ANILLO 15HH	96012A0021	1	-
12	PLATO INTERMEDIO ANILLO 20HH	9601200021	-	1
13	ROTOR I 15 HH 180mm	9602000021	1	-
13	ROTOR I 20 HH 195mm	9601000021	-	1
14	EMPAQUE ARAND. ROTOR 1.1/2-6.6	7707000043	1	1
15	ARANDELA ROTOR	7706600044	1	1
16	ARANDELA COBRE 10 mm	8012500056	1	1
17	TORNILLO NC 3/8"x1"	7025100056	1	1
18	AROSSELLO REF 2-175	9602900051	1	-
18	AROSSELLO REF 2-177	9615000051	-	1
19	TAPA DELANTERA ANILLO 15HH	9601900021	1	-
19	TAPA DELANTERA ANILLO 20HH	9600500021	-	1
20	VALVULA DESAIREADORA VM	9406700046	1	1
21	TAPON MACHO 3/8"NPT BRONCE	9408800056	1	1

COMPONENTES SOPORTE COMPLETO L2

ITEM No.	DESCRIPCION	CODIGO	CANTIDAD
1A	EMPAQUE SOPORTE ROD. L2	9213700051	1
1B	RODAMIENTO 6206-2Z	8629200052	2
1C	SOPORTE L2	9213100021	1
1D	CUÑA DE 1/4"x32 mm.	7220500041	1
1E	EJE SOPORTE L2.	9213300041	1
1F	CUÑA DE 3/16"x25 mm	7707100041	1
1G	ANILLO RETEN. ROD. I-62	8102500052	2
1H	ANILLO RETEN. ROD. A-30	7615900052	1
1I	RETENEDOR 30x62x10	9213600051	1

- Tornilleria estandar se ilustra unicamente.