

5x20-15
5x20-20
5x20-25

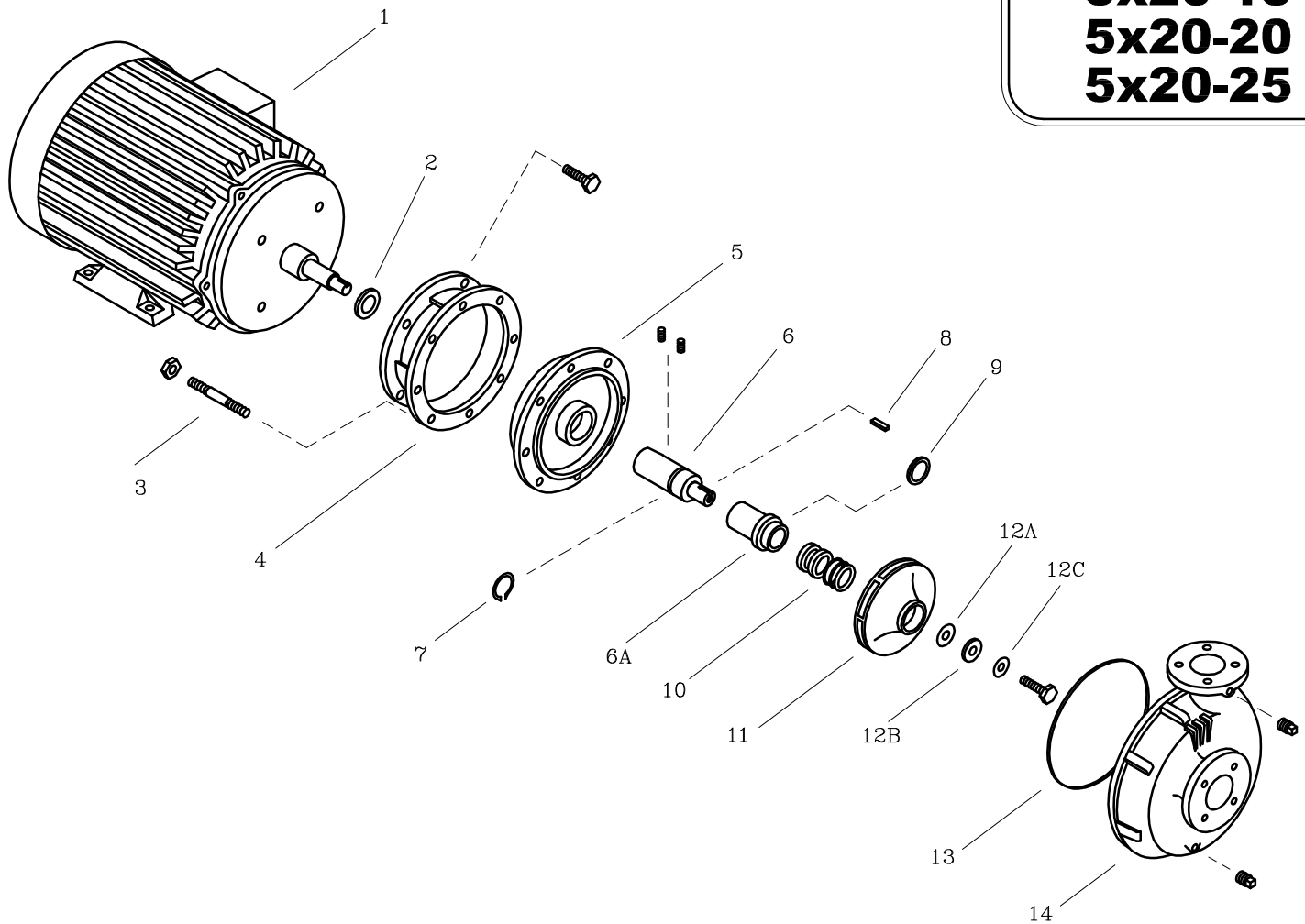

LISTA DE REPUESTOS			CANTIDAD		
ITEM No.	DESCRIPCION	CODIGO	5x20-15W	5x20-20W	5x20-25W
* 1	MOTOR ELECTRICO 3500 RPM.	SEGUN POTENCIA	1	1	1
2	DEFLECTOR 29.3 mm. DIA. INT.	7220000051	1	—	—
2	DEFLECTOR 43.5 mm. DIA. INT.	7800600051	—	1	1
3	ESPARRAGO NC. 1/2"x60 mm.	8604700044	8	8	8
4	ADAPTADOR 5x20-18.0	8917300021	1	1	1
5	PLATO SELLO 5x20-18.0	8917200021	1	1	1
6	EJE EXTENSION 5x20-18.0	8917600041	1	—	—
6A	CASQUILLO S.M. 5x20-24 AI	0302800041	—	1	1
7	ANILLO RETEN. ROD. A-38	8703500052	1	—	—
8	CUÑA ROTOR 1/4"x1/4"x30 mm.	8836400041	1	1	1
9	AROSSELLO ROTOR	7711300051	—	1	1
10	SELLO MECANICO ϕ 1.1/2" TIPO 21	7712000051	1	1	1
11	ROTOR 5x20-18.0 160 mm.	88352C0021	1	—	—
11	ROTOR 5x20-24.0 175 mm.	88352B0021	—	1	—
11	ROTOR 5x20-28.0 185 mm.	88352A0021	—	—	1
12A	EMPAQUE ARANDELA ROTOR 5x20	8836800043	1	1	1
12B	ARANDELA ROTOR 17/32" DIA. INT.	8836500041	1	1	1
12C	ARANDELA DE COBRE 17/32"	8837700056	1	1	1
13	EMPAQUE CARC. P/SELLO 4x13	9208600051	1	1	1
14	CARCASA ANILLO 5x20	8835100021	1	1	1

* Para servicio o reparacion del motor, tenga en cuenta el modelo y características contenidas en la placa del mismo.

— Tornilleria estandar se ilustra unicamente.